

Čapkova 22  
678 01 Blansko  
tel.: +420 516 416942, 419995  
fax: +420 516 416963

### DISPLAY MODULE WITH ACTIVE OUTPUT AND RELAY

- designed for mounting on DIN rail 35
- the input and the keypads are galvanically isolated from the power circuit, switching elements and output
- analog output according to 0 / 4..20mA, 0..10V or without output
- auxiliary power supply in the range of 19 to 300VDC and 90 to 250VAC
- setting limits by using the keyboard for up to 2 switching relays, input and its transfer
- view the signal display in the interval -999 ... 9999

The module is used to convert an active signal monitoring and alarm limit for 2 switching relays. Using the keyboard and display can be changed and the value of the switching relay opening, number of decimal places, and the filter according to the embodiment of the input signal and converting it:

**Variant R: Pt100, Pt1000, Ni100, Ni1000, resistance to 320Ω or to 2600Ω**

**Variant A: Current ±20mA, voltage ±10V and ±1V DC with user value conversions**

**Variant T: Thermocouple type J, K (other types upon request)**

**Variant P: Potentiometer to value 150Ω, 1kΩ, 11kΩ**

**Variant D: By design: sensors e.g. NTC, KTY, voltage from ±30mV to ±50VDC, current to ± 2A DC or resistor to 11kΩ**

#### **Electrical specifications:**

- operating temperature range: -30...+ 60°C
- input signal according to design: Pt100, Pt1000 by DIN IEC 751, Ni100, Ni1000, OV 0..320Ω, 0..2600Ω  
±1V, ±10V, ±20mA  
Thermocouple J (-50..900°C), K (-40..1200°C)  
Potentiometer 150Ω, 1300Ω a 11kΩ  
NTC, KTY, Tc (S, M, L, B..), voltage to ±50V, current to ±2A, resistance to 11kΩ  
< 10 Ω / 1 wire
- max. lead resistance for 3wire
- Input resistance of the voltage input: 1MΩ
- Input connections: 2 or 3 wire / two-wire for thermocouple
- input current input resistance: 27Ω
- current through the RTD sensor: < 0,5mA
- parameters for thermocouples: cold junction compensation: -40 ..80°C, accuracy ± 1°C
- output: active 0..20mA, 4..20mA, 0..10V
- output resolution: < 0,01%
- output limitation: 2,5..22mA, 0..22mA, 0..12,5V
- damping: 0,1..20s (nominal setting: OV, Pot < 0,2s, RTD, Tc 0,3s)
- accuracy: error: ±(0,07% +0,1°C)  
temperature drift: 0,03%/10K  
non-linearity: 0,012%, Tc: 0,1%, Tc J: 0,3°C
- storage temperatures: -40..+80°C
- supply voltage: standard: 19 – 300VDC a 90 – 250 VAC  
on request: 20 – 60VAC
- power consumption: max. 2VA
- Output loop excitation: min. 15V (Rz = 750ohm for 20mA)
- voltage output load: max. 10mA
- current input voltage drop: 0,54V for 20mA
- coverage cabinet / terminal box: IP40 / IP10
- weight: 150g
- relay parameters: switching contact, load max. 230V AC/ 60V DC, max. 5A  
minimum switching values 100mA by 5V DC  
relay I. closed - red LED  
relay II. closed - green LED
- signaling
- electrical insulation strength: 4000Vef, 50Hz/1 min – power against output contacts and input  
4000Vef, 50Hz/1 min – input against output contacts
- environment: degree of pollution 2, installation overvoltage class III

#### **Software:**

The program menu consists of the following basic functions:

- Mode [rE]** - 0: measuring mode, 1: service mode ( without relay control )
- Input [In]** - selection of the conversion characteristic for the input signal (see tab. 1)
- Decimal point [dt]** - position of the decimal point in the display
- Conversion function** - they do not contain temperature inputs
- [IL], [Ir]** - lower range of input range and range (e.g.. 4.00=IL, 16.00=Ir (the input range is 4-20mA))
- [CL], [Cr]** - lower limit display value [IL] and displayed range [Ir]
- Upper limit [H1, H2]** - setting an upper limit switching relays I. a II.
- Lower limit [d1, d2]** - setting an lower limit switching relays I. a II.
- Output current [oi]** - output setting 0=> 0..20mA, 1=> 4..20mA

**Output [oL, or]** - lower range of output range and range e.g. 0..100°C/0..10V  
**Filter [Fi]** - damping in the interval <0,1.. 22s> (change time from 0 to 63%)

- \*) item is not listed if the input signal is temperature
- \*\*) the item is listed in the menu only for current output

Entry to the program menu is gained by simultaneous keypresses \* and ↓

The display shows the function MODE (mark rE) and then you can switch (0 – standard mode, 1 – service mode). This opens the entry into the program menu. Switching between functions is possible only in one direction i.e. only in the direction indicated in the figure by simultaneously short press \* and ↓.

Entry to the setting of the function is done by pressing button →. The display shows a four-digit function value. The first step is to set the highest order numbers, which can be changed by the button ↓ and over and over again in descending order. Another pressing button → we move to set the digit in lower order, the set digit always blinks. In the same way, to set the remaining digits. Only after pressing the button → when the lowest order flashing, the value is written to the instrument, this is how the function setting is completed. Now you can continue by selecting the function on the main menu bar.

Cancellation of setting values can be done by simultaneously pressing \* and ↓ before saving to your device. In this way we go to the next function without saving the value to the device.

By scrolling through the main menu of the program menu, there are no changes to the settings and this can be used to check the device settings.

In the following description, the feature will be marked with the mark that appears on the display (enumerated in square brackets).

#### Function **MODE [rE]**

For proper operation of the instrument, it is necessary to set the function value to 0. The value 1 is only for the service mode.

#### Function **INPUT [In]**

This function determines the type of the measured quantity. The value depends on the design and the value given in Table 1 or the label of the instrument.

#### Function **DECIMAL POINT [dt]**

This function determines the position of the dots displayed on the display. For [dt] = 0, the shape of the xxxx., For [dt] = 1 has the shape number xxx.x, etc.

#### Function **DISPLAY CONVERSION [IL, Ir, CL, Cr]**

This group of values used to convert the input signal to the desired view. We can describe it by:  $y = (x - [IL]) / [Ir] * [Cr] + [CL]$ . The input interval is set by lower value [IL] and its range [Ir]. E.g. input 4..20mA save the numbers to de device [IL]=4 and [Ir]=16. The value that is displayed is the interval given by the minimum [CL] and range [Cr]. E.g. for display range 300...1300 we save to the device numbers [CL]= 300 and [Cr]=1000.

If you do not want to make a conversion, just enter value [IL]=0, [Ir]=100, [CL]=0, [Cr]=100.

Note: values respect the decimal point values set in the previous step.

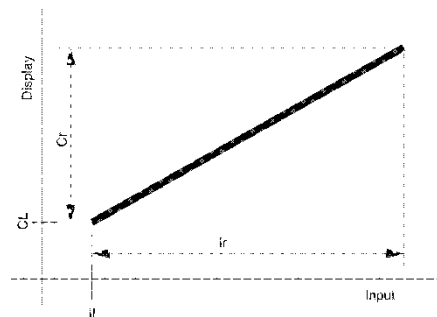

#### Function **UPPER LIMIT and LOWER LIMIT [H1/H2 and d1/d2]**

These functions are closely related. Their settings can affect the relationship in case of power failure and a zero signal. The following pictures show the interrelation.

Relay ON

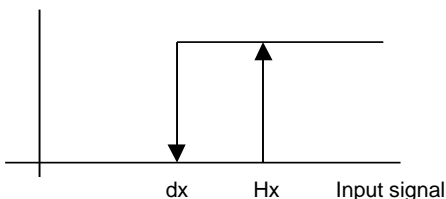

Relay ON

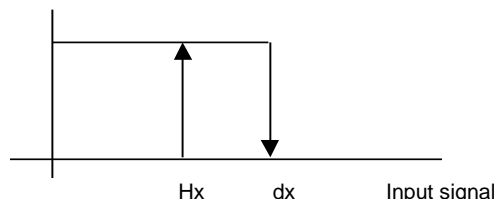

We recommend changing the limits within the input signal range. If [dx] = [Hx], [dx] is automatically set by 1/2 digit below. The limits are set in the indicated units. The device has two independent limits. They are labeled 1 and 2. In the settings menu, then the device indicates **[H1]/[d1] a [H2]/[d2]**.

#### Function **OUTPUT CURRENT [oi]**

Function for switching current output 0 => 0..20mA, 1=> 4..20mA

#### Function **OUTPUT [oL, or]**

Function for setting the output signal. Function [oL] stores the value input at which the output signal should be at the lower and function [or], then the measured range. E.g. for range -20..100°C [oL]=-20 and [or]=120.

Note: When used Conversion function, the value set in the displayed values.

#### Function **FILTER [Fi]**

change from 0 to 63% of the value for a time in the interval <0,1..22s>

Control menu:

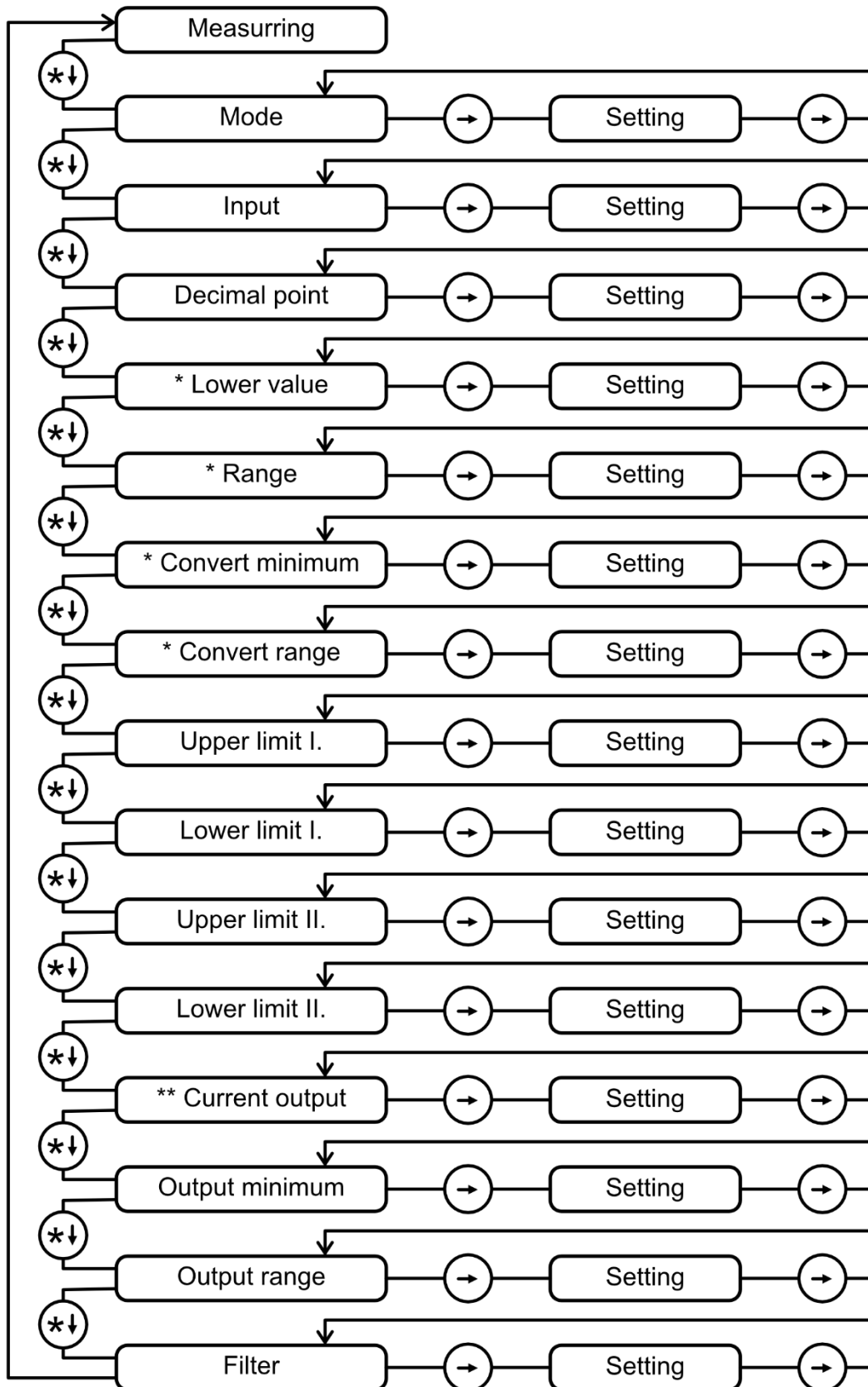

\*) the item is not listed in the menu if the input signal is temperature

\*\*) the item is listed in the menu only for current output

### Installation:

The application wiring of the limit switch for the individual input signals is shown in the figure. The terminal block used allows connecting conductors up to a 3.5 mm<sup>2</sup> cross section. We recommend to use a cable with a core cross section of 1.5 or 2.5 mm<sup>2</sup> depending on the desired winding resistance. The screw terminals are M2,5 screws, it is therefore necessary to use **only an adequate force to tighten the clamp**.

Mechanically, the transducer is mounted on a 35 mm DIN rail. First mount the housing with the upper part of the DIN rail. Then, with the screwdriver, lower the latch and press the housing on the DIN rail. After releasing the screwdriver and locking the spring mechanism, the assembly is over.

### Terminal connection:

1..3 Relay 1  
 4..6 Relay 2  
 10..12 Input  
 13(-), 14(+): Output 0..10V, 0/4..20mA  
 19,21: Supply 230V AC, 24VDC

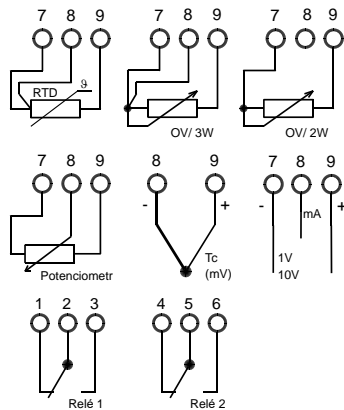

### Dimension:

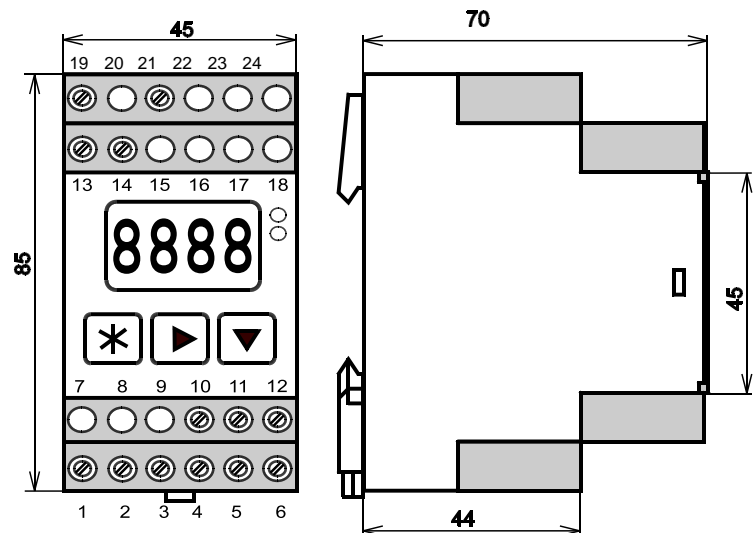

Table 1.

Type of variable and range by function In				
	DIGIREG 03.R - RTD	DIGIREG 03.T - Tc	DIGIREG 03.A - UI	DIGIREG 03.P - Potenciometr
0	Pt100 2W, -99..600°C	Tc J, -50..920°C	±1V	0..150Ω
1	Pt100 3W, -99..600°C	Tc K, -40..1260°C	±10V	0..1300Ω
2	Pt1000 2W, -99..450°C	-9,99..73mV	±20mA	0..11kΩ
3	Pt1000 3W, -99..450°C			
4	Ni100 Tk 5k 2w, -60..250°C			
5	Ni100 Tk 5k 3w, -60..250°C			
6	Ni1000 Tk 5k 2w, -60..250°C			
7	Ni1000 Tk 5k 3w, -60..250°C			
8	Ni100 Tk 6k8 2w, -60..250°C			
9	Ni100 Tk 6k8 3w, -60..250°C			
A	Ni1000 Tk 6k8 2w, -60..250°C			
b	Ni1000 Tk 6k8 3w, -60..250°C			
C	Resistor 2w, 0..320Ω			
d	Resistor 3w, 0..320Ω			
E	Resistor 2w, 0..2600Ω			
F	Resistor 3w, 0..2600Ω			

Table 2

Outputs DIGIREG 03			
	Relay I.	Relay II.	U/I output
0	Yes	-	-
1	Yes	Yes	-
2	Yes	Yes	Yes
3	Yes	-	Yes
4	-	-	Yes
5	-	-	-

Table 3

Analog output		
	0/4-20mA	0-10V
A	Yes	-
B	-	Yes
C	-	-

**Type tests:**

Basic type test: according ČSN EN 60770-1 ed.2  
 EMC: according ČSN EN 61326-1 ed.2  
 Safety: according ČSN EN 61010-1 ed.2

**Ordering:**

Variants of inputs of standard devices supplied by [tab. 1](#)  
 inputs of varietal D must be discussed before ordering!  
 Outputs: combination without relay, 1x relay, 2x relay, analogue output [tab. 2](#)  
 Analog output: 0 / 4..20mA, 0..10V or without output [tab. 3](#)

The ordered input specification can be changed in the range of uploaded linearizations,

e. g.: for R, Table 1 applies to the first column.

The ordered output specification is factory set and can not be changed and must be selected when ordering.

Special requirements need to be discussed in advance.

**Examples:**

2ks <b>DIGIREG 03.A14B</b> 0-10V	= input 0-10V, without relay/output 0-10V
1ks <b>DIGIREG 03.R12A</b> Pt100 / 4-20mA	= input Pt100 3w, 2x relay, output 4-20mA
4ks <b>DIGIREG 03.R02A</b> 0..250°C /0-20mA	= input Pt100 2w, 2x relay, output 0-20mA
3ks <b>DIGIREG 03.T20C</b> 0..1200°C	= input Tc"K", 1x rele, without analog output
1ks <b>DIGIREG 03.P11C</b> 0-1k Ohm	= input potentiometer 0-1k Ohm, 2x relay, without analog output
1ks <b>DIGIREG 03.A22A</b> 4-20mA / 4-20mA	= input 4-20mA, 2x relay, output 4-20mA
2ks <b>DIGIREG 03.Dx3B</b> 0-2A / 0-10V	= input 0-2A, 1x relay, output 0-10V



Dispose of disposal after end of life by separate collection.  
 Rawet s.r.o. is a member of the association RETELA [www.retela.cz](http://www.retela.cz)